

RMC SENSOR TELEMETRY

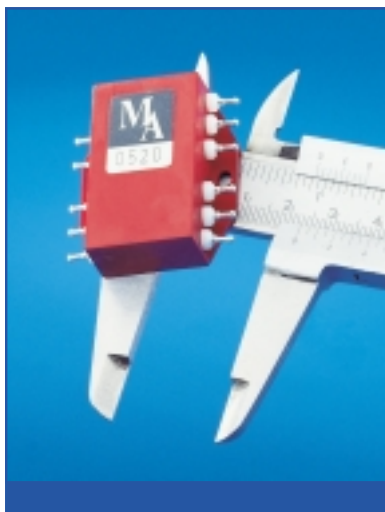

FEATURES

- Remote-Controlled Measuring Range Selection
- Remote-Controlled Zero Adjustment
- Remote-Controlled Shunt Calibration
- No Batteries Required, Integrated Energy Coupling
- Easy to Assemble and Operate
- Measuring Signal Bandwidth 0 ... 40 kHz (-3 dB)
- Any Shaft Diameter Possible
- Suitable for all Conventional Sensors
- Speed and Performance Measurement
- Exceptional Environmental Friendliness
- Serial Interface



SENSOR SIGNAL AMPLIFIER

The Sensor Signal Amplifier (rotor electronic unit) is sealed inside an environmentally friendly aluminium housing. Massive soldering pins guarantee high solder security. If space is at a premium during installation, a hybrid version is also available (32 x 15 x 10 mm). The sensors are connected directly to the rotor electronic unit. A load amplification module can also be optionally integrated in the case of piezosensors. A carrier frequency module is also available for LVDTs.

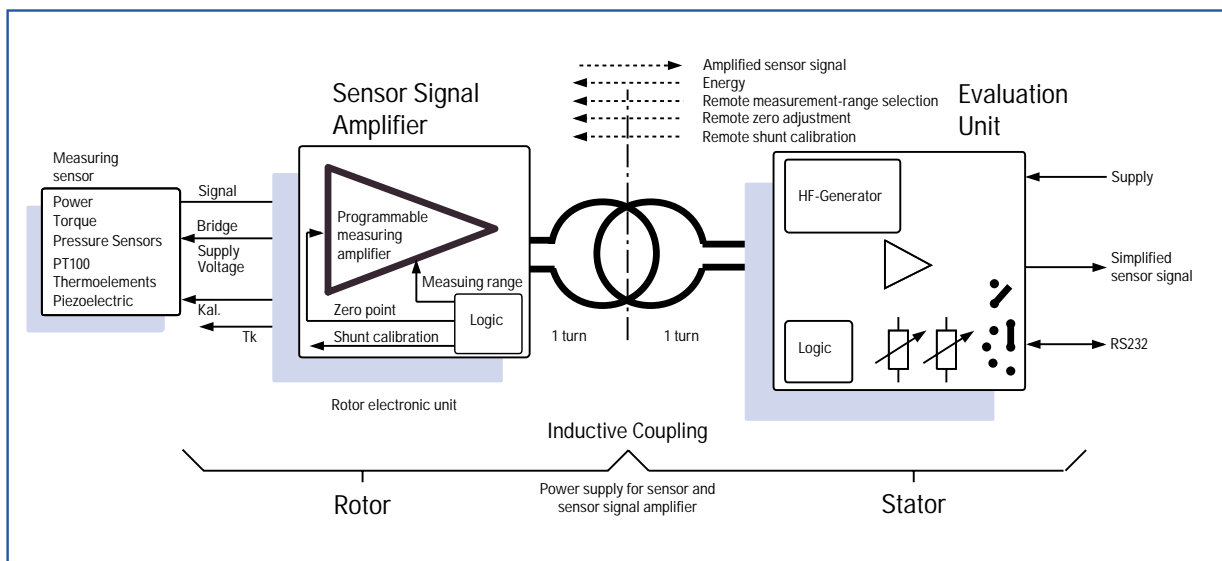

CONTACTLESS ...

The measuring signal is transmitted inductively.

In the basic version, the bidirectional line is made up of two massive wire loops (stator and rotor one turn each respectively). The loops can also be designed as divisible solid rings. As well as the basic version, the stator ring is also available as a compact antenna. A special variant features the rotor ring integrated as a compact element into the sensor signal amplifier.

The distance between the reception antenna and the evaluation unit can be up to 30 m (100 ft). A simple coaxial cable (type RG 58 or RG 316) can be used as a connecting lead.

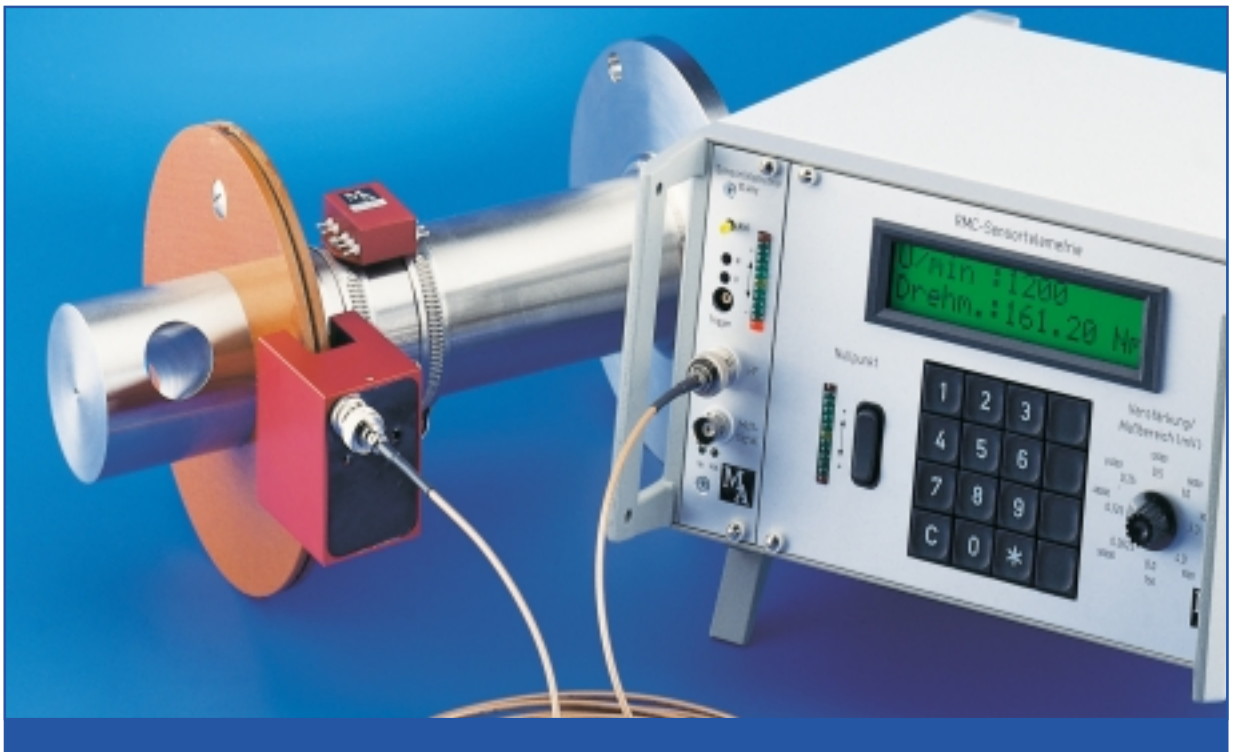
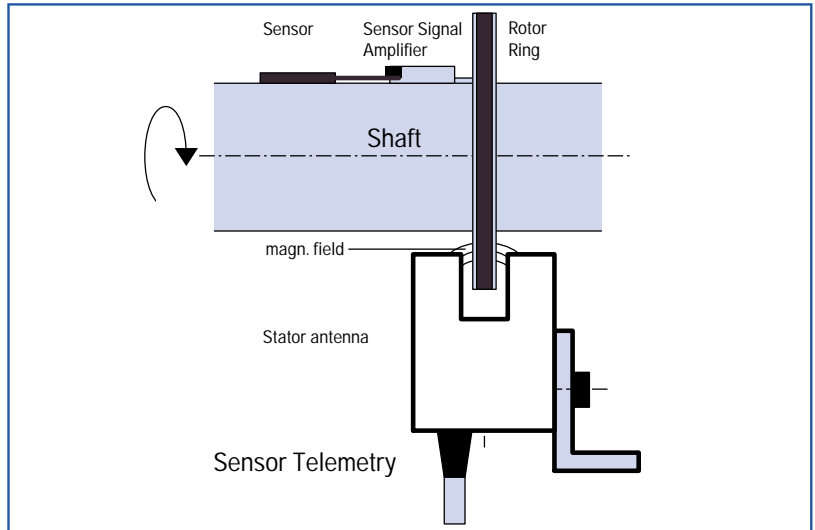

THE EVALUATION UNIT

The evaluation unit converts the digital transmission signal into an analogue output signal (0 ... +/- 10 Volt, 50 Ohm). The output signal can then be processed further directly via transient recorder, PC or oscilloscope. The following forms of output signal are available:

- Voltage signal 0 ... +/- 10 V
- Current signal 0 (4) ... 20 mA
- Frequency signal 50 ... 150 kHz
- Serial interface RS232 / RS422

As well as preparing measuring signals, the evaluation unit also provides the RF energy for the rotor electronic unit and the sensor. The control information (measuring range, remote calibration, zero point and type of sensor) is prepared digitally and serially via inductive coupling.

All controls are on the front of the unit. The integrated microcontroller with liquid crystal display allows measurement data to be directly displayed in the relevant units (Nm, °C, $\mu\text{m}/\text{m}$, m/s^2). Measuring signals may also be optionally read off the back of the unit.

The respective scale readings can be entered via the keyboard. Switching the unit off does not affect its settings.

Speed Measurement (optional)

The integrated speed measurement function allows the speed of the dynamo hub to be monitored via a display. Evaluation is based on one speed mark per revolution. Period measurement guarantees brief measuring times.

Performance Measurement (optional)

The performance of the dynamo hub can be determined via the integrated speed and torque measurement. The current performance level is displayed in "performance measurement" mode.

Serial Interface (optional)

The unit can be entirely controlled by PC via a serial interface. Furthermore, all measurement data can be transmitted. This is particularly advantageous if the data needs to be processed further via PC.

The unit is available in three versions:

- tabletop unit
- 19" plug-in unit
- European standard size PC board plug-in unit

Alongside the standard 90 ... 270 V AC power supply, optional 12 V and 24 V airborne supply variants are also available.



APPLICATIONS...

The RMC sensor telemetry system has been specially developed for the contactless (telemetric) detection of measuring data on moving objects - particularly rotating shafts - employed in the mechanical engineering industry. The remote-controlled rotor electronic unit (sensor signal amplifier) and the simple method of transmission (antennae) make the system exceptionally user friendly. Remote-controlled measurement range selection means that the usual problems caused by selecting the wrong measurement range on a rotor electronic unit are eliminated. RMS sensor telemetry is ideal for research applications both inside and outside the laboratory, and also for bench tests.

A SAMPLE APPLICATION

Torque measurement in gear

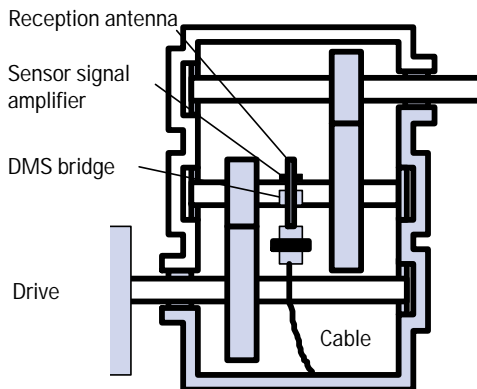

The system has the following variables included:

- Short start-up times
- No solder resistance on rotor electronic unit
- Free choice of measuring range and zero adjustment during operation
- Higher resolution of measuring signal due to dynamic measuring range selection
- Integrated speed and performance measurement for dynamo hubs

Typical physical measurable variables include:

- Torque
- Power
- Pressure
- Temperature
- Acceleration
- Linear deformation

The Sensors

Any conventional sensors may be connected to the sensor signal amplifier without the need for any extra amplification:

- DMS sensors (quarter, half and full bridge)
- Thermoelements NiCr.-Ni
- PT100 sensors
- Pressure sensors
- Piezosensors

The power supply for the rotor electronic unit and the evaluating unit is integrated and takes place inductively. No batteries are used. Transmission is based on the transformer principle. Inductive transmission allows transmission of measuring signals, without the use of batteries, up to max. 200 mm.

SENSOR TELEMETRY - THE DIVIDED, ROTARY-TRANSFORMER TYPE MEASURING AMPLIFIER...

Sensor telemetry is actually a measuring amplifier divided into two by a rotary transformer. The input amplifier (rotor electronic unit) is mounted right at the measuring sensor itself and amplifies the measuring signal, thus ensuring distortion-free transmission. The output amplifier (stator electronic unit) further amplifies the measuring signal and transfers it on to evaluation units, allowing the fine adjustment of amplification and zero point.

ADVANTAGES OVER SLIP-RING TRANSMISSION...

The transmission technology is ideal for long-term measurement because it never needs to be serviced and involves no wear and tear whatsoever. The RMC sensor telemetry system is thus a more than merely interesting alternative to slip-ring transmission.

TECHNICAL SPECIFICATIONS:

System Data	Type of bridge: Full or half bridge	Evaluation Unit:
RF carrier frequency: 13,56 MHz	Drift: +/- 0,01 % / ° Centigrade	Output signal: 0 ... +/- 10 V, BNC
Transmission method: inductive coupling	+/- 0,003 % / ° Centigrade (optional)	Drift: < 0,005% / ° Centigrade (0 ...70°)
Carrier frequency: 100 kHz		Speed: 1 mark/rev. (optional)
Frequency deviation: 50 kHz	Environment:	Performance: reading displayed (optional)
Channel bandwidth: 0 ... 1 kHz (-3dB)	Temperature: - 10 ° ... + 85 ° Centigrade	Remote measuring range selection:
alternatively: 0 ... 10 kHz (-3 dB)	Optional: - 45 ° ... + 125 ° Centigrade	8-step switch
alternatively: 0 ... 40 kHz (-3 dB)	Enclosure: IP67	Amplification (fine): trimmer
Extension filter: 0 ... 100 Hz, connectable	Max acceleration: 10.000 g	Remote zero point (rough): digitast
Channel dynamics: 73 dB (at 100 Hz band-		Zero point (fine): trimmer
width and measuring range 1 mV / V)	Housings:	Remote shunt calibration: modulator
Amplification: 100 100 000	Material: aluminium	Type of sensor: switch (optional)
Linearity: < 0,05 %	Dimensions: 34 mm x 22 mm x 12 mm	Computer control: RS232, RS422 (optional)
	Connections: terminal pins	Temperature range: -25 ° ... +85 ° Centigrade
Sensor Signal Amplifier	Weight: 15 g	Power supply: 90 ... 270 V AC
Measuring range: remotely adjustable from		Airborne supply:
evaluation units (8 steps)	Material: epoxy resin	12 (8...18) volts / 24 (18 ... 36) volts (optional)
Input sensitivity: 0,05 mV / V ... 8 mV / V	Dimensions: 32 mm x 15 mm x 11 mm	Housing: tabletop unit, 19" plug-in unit,
Input voltage: +/-0,2 mV ... +/- 24 mV	Connection: solder pads	European standard size PC board plug-in
Zero point: remotely adjustable from evaluation unit	Weight: 10 g	unit
Zero point displacement area:	Sensor power supply:	Coupler (reception antennae)
0 ... +/- 500 % of measuring range selected	Voltage: 2,5 V +/- 0,01 % / ° Centigrade	Type 2, type 9, type 7
(input resistance = 10 kOhm)	current (max.): 18 mA	Maximum distance
DMS resistance: 350, 1000 Ohm		Evaluation unit reception antenna: 30 m