

Ethernet multifunction counter system

4 EnDat counter inputs, 16 digital I/O, 24 V

EnDat 2.2



MSX-E1731

4 EnDat 2.2 inputs

16 digital I/O, 24 V, with status LEDs

24 V digital trigger input

M12 connectors



Integrated Ethernet switch



*Operating temperature



ARM⁹ Technology

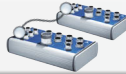

Cascadable, can be synchronised in the μ s range

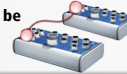

On request: Compare logic for synchro trigger signal



on request



DatabaseConnect on request



More information at www.addi-data.com

Features

- 24 V digital trigger input
- ARM⁹ 32-bit processor
- 64 MB onboard SDRAM for storing data
- Robust standardized metal housing
- Power Save Mode: Reduced power consumption when no acquisition runs

Safety features

- Status LEDs for fast error diagnostics
- Optical isolation 1000 V
- Input filters

Sensor inputs

- 8-pin M12 female connectors
- 4 x EnDat counter inputs for the acquisition of EnDat encoders
- Max. clock frequency 4.5 MHz
- Voltage supply of the EnDat encoders via M12 female connectors: 5 V \pm 10%
- Output of the values as raw value or position value (mm or $^{\circ}$)
- Communication LED for each EnDat input

Interfaces

- Fast 24 V trigger input
- Ethernet switch with 2 ports
- Synchronisation/trigger In/Out
- Line in for 24 V supply and cascading

Communication interfaces

- Web server (configuration and monitoring)
- Command server SOAP for transferring commands
- Data server (TCP/IP or UDP socket) for sending acquisition data
- Event server (TCP/IP socket) for sending system events (Diagnostics such as temperature, short-circuits ...)
- Command server Modbus TCP and Modbus (UDP) for sending commands

Synchronisation/time stamp

Time stamp

Several MSX-E systems can be synchronised with one another in the μ s range through a synchro connection. This allows to start a synchronous data acquisition, to generate trigger events and to synchronise the time on several MSX-E systems. Furthermore, the systems have a time stamp that logs the point in time at which the data was acquired by the system.

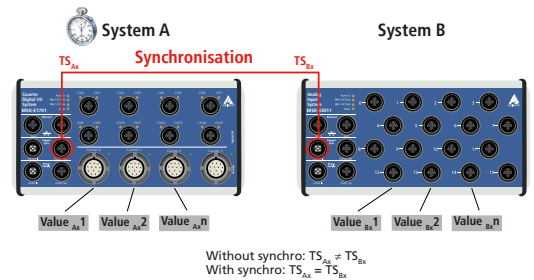

The combination of synchronisation and time stamp (TS) allows the clear allocation of signals that were captured by several systems.

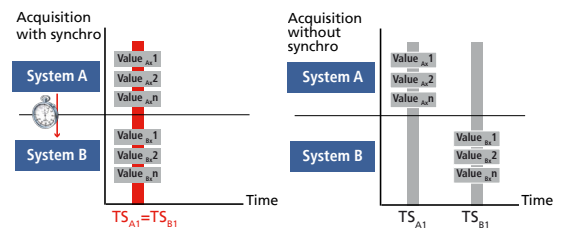

EnDat

EnDat is a bidirectional synchronous-serial interface for position measurement devices. This interface allows to read out absolute position values and parameters, to write status and initialisation registers and to transfer additional information about the position value. In addition, ADDI-DATA EnDat 2.2 solutions support the evaluation of diagnostic values and access to the OEM memory. Data is transferred serially.

- Fast data transfer
- Signal delay time compensation
- High contour accuracy
- High transmission safety
- No need for additional sensors: Evaluation (temperature, limit switch, etc.)
- Serial transmission: only 4 lines necessary (EnDat 2.2)
- Single-line wiring (M12, 8-pin)
- Automatic parameterisation through electronic type plate

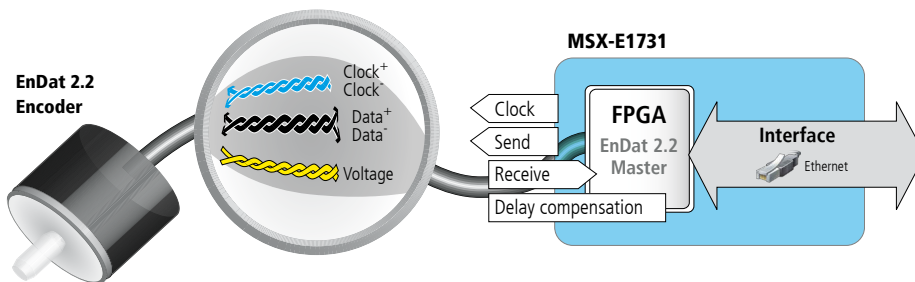

Acquisition modes

There are two different acquisition modes for EnDat sensors:

Asynchronous acquisition

With the asynchronous acquisition, the EnDat sensors can be read out after initialisation via SOAP or Modbus function. For each function call, one position value is transmitted. EnDat 2.2 also allows to read out additional sensor-specific values (e. g. temperature,...)

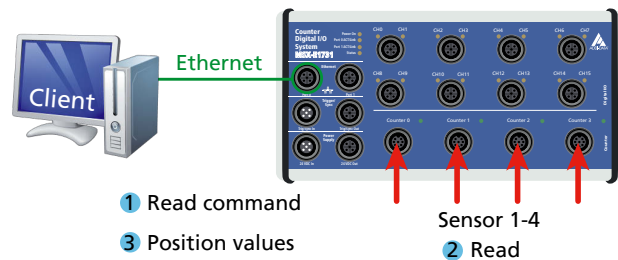

Synchronous acquisition

With the synchronous acquisition, at first the sensors are initialised and then the acquisition is parameterised. The acquisition runs automatically in relation to a trigger source. Either the 24 V trigger input or a Synchro timer can be used as a trigger source. When using the Synchro timer, a periodical acquisition of the EnDat inputs is also possible.

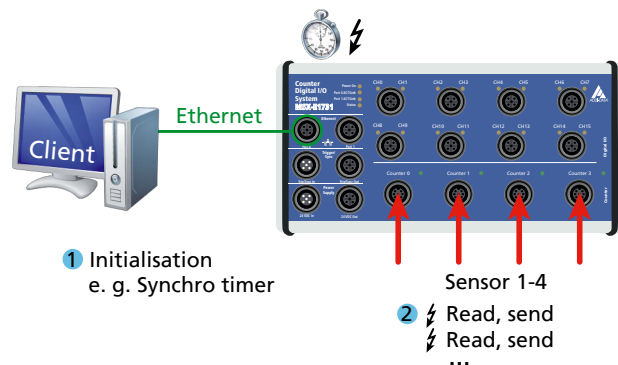

With the synchronous acquisition, it is possible to acquire all 4 sensor inputs of the MSX-E1731 simultaneously. It is also possible to combine several MSX-E systems (even of different types) through the Synchro trigger. In synchronous acquisition mode, measurement data is sent to the clients as soon as it is available via a socket connection.

Onboard programming / stand-alone operation

Development mode

With the Development mode of the MSX-E systems you can customise your measurement, control and regulation applications to fit your requirements. The programs run directly on the MSX-E systems, which has two advantages: external PCs are relieved and you can process data freely according to your requirements. This helps you to improve the efficiency of your processes and to secure your investments.

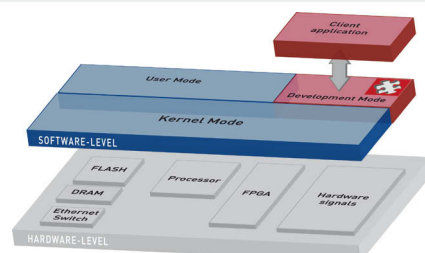

ConfigTools

The **ConfigTools** program allows an easy administration of the MSX-E systems. These are automatically detected in the network. **ConfigTools** consists of common and specific functions. In addition, with **ConfigTools**, the complete configuration of a MSX-E system can be saved and transferred to another system of the same type (clone function).

ConfigTools is included in the delivery.

ConfigTools functions for MSX-E1731:

- Change of IP address
- Display of web interface
- Firmware update
- Save/load system configuration
- Save/load channel configuration

Very easy use through the „ConfigTools“ program; The MSX-E system is automatically detected in the network.

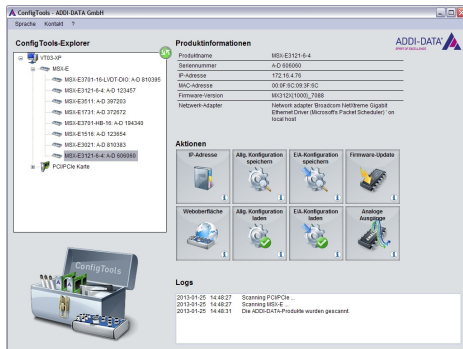

Features

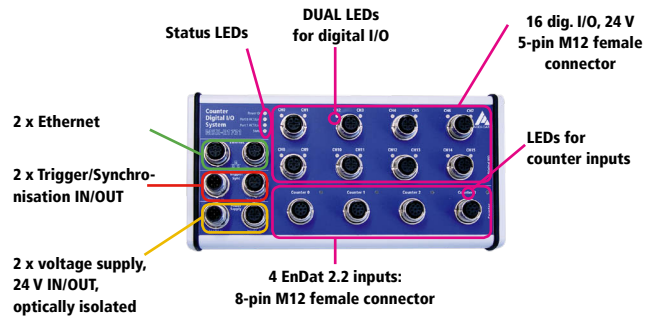

Simplified block diagram

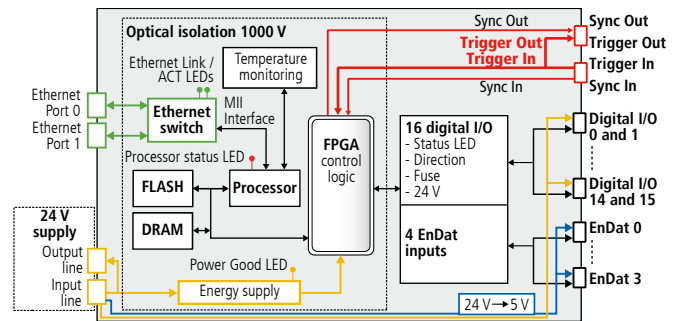

Cascading

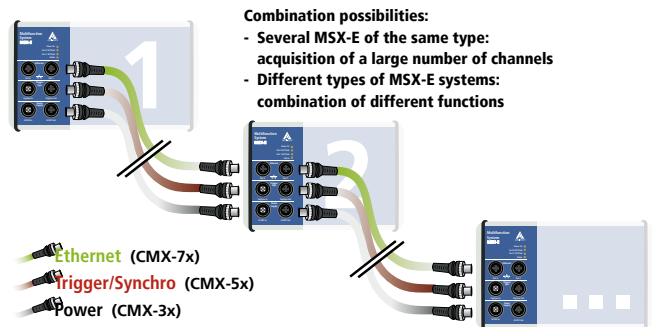

ADDI-DATA connection technology

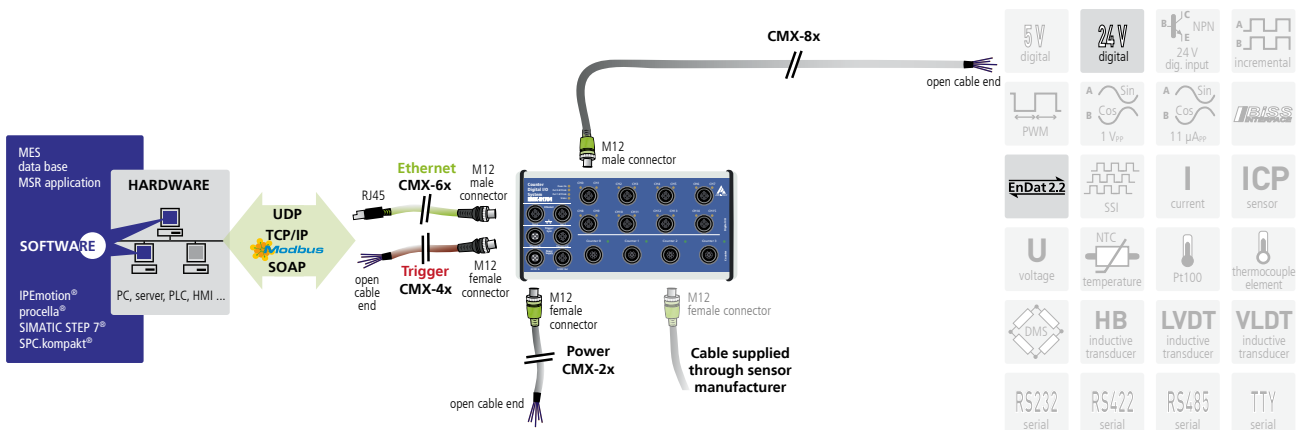

Specifications

Counter inputs

Input type:	EnDat 2.2
Differential inputs:	Complies with the EIA standards RS422A
Input type:	Differential
Common mode range:	+12 / -7 V
Input sensitivity:	± 200 mV
Input hysteresis:	50 mV typ.
Input impedance:	12 k Ω min.
Max. input frequency:	5 MHz
ESD protection:	Up to ±15 kV
Clock frequencies:	4500 kHz 2500 kHz 1500 kHz 900 kHz 500 kHz

Digital inputs

Number of inputs:	max. 16, 2 per M12 female connector, common ground acc. to IEC 1131-2
Overvoltage protection:	30 V
Optical isolation:	1000 V through opto-couplers
Nominal voltage:	24 VDC
Input voltage:	from 0 to 30 V
Input impedance:	> 1 M Ω
Logic input levels:	UH (max): 30 V typ. UH (min): 18 V typ. UL (max): 16 V typ. UL (min): 0 V typ.

Digital outputs

Number of outputs:	max. 16, 2 per M12 female connector
Optical isolation:	1000 V through opto-couplers
Output type:	High-side, load to ground acc. to IEC 1131-2
Nominal voltage:	24 V
Voltage supply:	18 V-30 V
Current (max.):	1.85 A typical for 8 channels through PTC
Output current / output:	500 mA max.

Short-circuit current / output:	1.7 A max. Shut-down logic at 24 V, Rload=10 m Ω
RDS ON resistance:	280 m Ω max.
Switch-on time:	100 μ s max RL=48 Ω from 80 % Vout
Switch-off time:	150 μ s max RL=48 Ω from 10 % Vout
Overtemperature (shutdown):	135°C max. (output driver)
Temperature hysteresis:	15°C typ. (output driver)
Diagnostics:	Common diagnostics bits for all 16 channels at overtemperature

Watchdog

Number:	1
Resolution:	16-bit
Time base:	μ s, ms, s (programmable)
Time value range:	1 to 65535

Voltage supply, Ethernet, Trigger, Synchro

The specifications for the voltage supply, Ethernet, Trigger, Synchronisation and Electromagnetic Compatibility apply to all MSX-E systems. See page 31.

System features

Interface:	Ethernet acc. to specification IEEE802.3
Dimensions (mm):	215 x 110 x 54 mm
Weight:	approx. 900 g
Degree of protection:	IP 65
Current consumption at 24 V:	150 mA without load
Operating temperature:	-40 °C to +85 °C
Connectors for sensors	
Digital I/O:	8 x 5-pin M12 female connector
Counter inputs:	4 x 8-pin M12 female connector

Ordering information

MSX-E1731

Ethernet multifunction counter system, 4 EnDat counter inputs, 16 digital I/O. Incl. technical description, software drivers and ConfigTools.

Connection cables

Voltage supply

CMX-2x: Shielded cable, M12 5-pin female connector/open end, IP 65

CMX-3x: For cascading, shielded cable, M12 5-pin female connector/male connector IP 65

Trigger/Synchro

CMX-4x: Shielded cable, M12 5-pin female connector/open end, IP 65

CMX-5x: For cascading, shielded cable, M12 5-pin female connector/male connector IP 65

Ethernet

CMX-6x: CAT5E cable, M12 D-coded male connector/RJ45 connector

CMX-7x: For cascading: CAT5E cable, 2 x M12 D-coded male connector

Connection to peripherals

CMX-8x: For the digital I/O, shielded cable, M12 5-pin male connector/open end, IP 65

Options

S7 Modbus TCP Client Library for S7:

Easy use of the Ethernet systems MSX-E with PLCs

MSX-E 5V-Trigger: Level change of the trigger inputs and outputs to 5 V
MX-Clip, MX-Rail (Please specify when ordering!), **MX-Screw, PCMX-1x**