

www.aep.it DCVTC4

Dynamometer with build-in display

Accessori Accessories

A

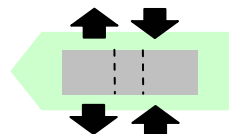
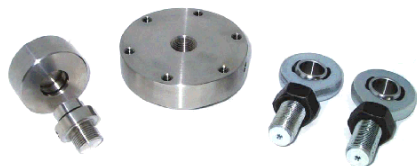

Load	Display	Ris.
0.5 t	0.5000 t	0.1 kg
1 t	1.000 t	1 kg
2.5 t	2.500 t	1 kg
5 t	5.000 t	1 kg
10 t	10.000 t	1 kg
20 t	20.000 t	1 kg
30 t	30.00 t	10 kg
50 t	50.00 t	10 kg
75 t	75.00 t	10 kg
100 t	100.00 t	10 kg



RoHS
COMPLIANCE

≤ ± 0.05%

Accuratezza
Accuracy



Certificato SIT a richiesta
SIT certificate on request

Dinamometro a basso profilo
Low profile Dynamometer

Alta stabilità a lungo termine
Long term high stability

Interamente saldata al LASER
Completely LASER welded

Dimensioni Dimensions

[mm]



CODE	LOAD	ØA	B	C	ØD	ØE	F	G	n° G	H
CDCVTC4100500K	0.5 t	100	86	35	72	32	M20X1.5	9	6	139
CDCVTC41001T5M	1 t									
CDCVTC41002T5M	2.5 t									
CDCVTC41275T5M	5 t	127	110	35	92	47	M30X2	10.5	8	166
CDCVTC412710T5M	10 t									
CDCVTC416520T5M	20 t	165	138	50	108	62	M42X3	17	12	204
CDCVTC416530T5M	30 t			60						
CDCVTC416550T5M	50 t									
CDCVTC423075T5M	75 t	230	185	80	145	98	M60X3	26	12	269
CDCVTC4230100T5M	100 t									

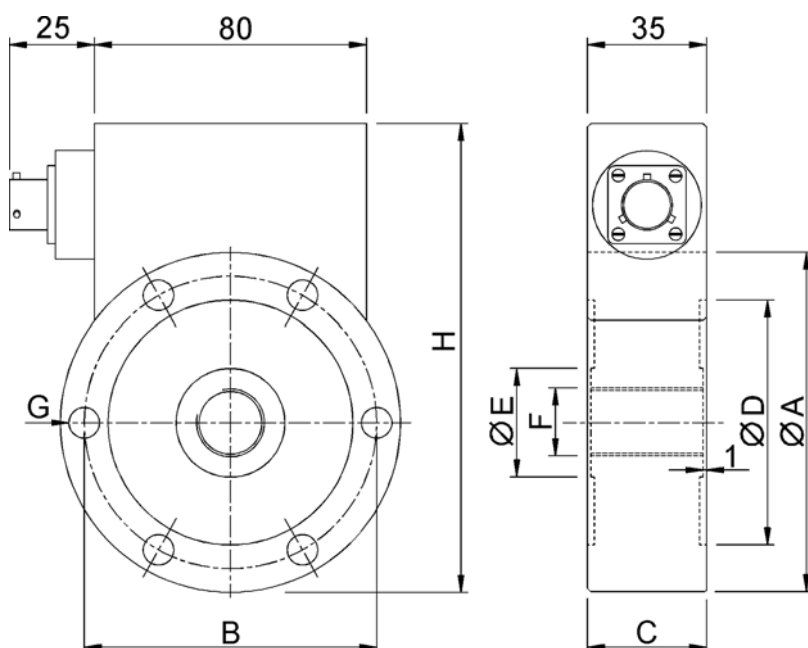

Dati Tecnici

Technical Data



Accuratezza	Accuracy	≤ ± 0.05% F.S.				
CARICO NOMINALE	NOMINAL LOAD	0.5-1-2.5t	5-10 t	20-30 t	50 t	75-100 t
LINEARITA'	LINEARITY	≤ ±0.05% F.S.				
ISTERESI	HYSTERESIS	≤ ±0.05% F.S.				
RIPETIBILITA'	REPEATABILITY	≤ ±0.02% F.S.				
RISOLUZIONE INTERNA	INTERNAL RESOLUTION	40.000 div.				
CONVERSIONI AL SECONDO	READINGS PER SEC.	2 (500ms)				
TEMPERATURA DI RIFERIMENTO	REFERENCE TEMPERATURE	+23°C				
CAMPO NOMINALE DI TEMPERATURA	TEMPERATURE NOMINAL RANGE	-10/+40 °C				
TEMPERATURA DI ESERCIZIO	SERVICE TEMPERATURE	-10/+70 °C				
TEMPERATURA DI STOCCAGGIO	STORAGE TEMPERATURE	-20/+80 °C				
EFFETTO DELLA TEMPERATURA (10°C)	TEMPERATURE EFFECT (10°C)	a) on zero b) on sensitivity				
a) sullo zero		≤ ±0.028% F.S.				
b) sulla sensibilità		≤ ±0.024% F.S.				
EFFETTO CARICO TRASVERSALE:	EFFECT OF TRANSVERSE LOAD:	a) at 10% of nominal load				
a) al 10% del carico nominale		≤ ±0.030% F.S.				
FUNZIONE DI ZERO REGOLABILE	ADJUSTABLE ZERO FUNCTION	± 10% F.S.				
DISPLAY ROSSI (alta efficienza)	RED DISPLAY (high efficiency)	7 segments				
ALTEZZA DISPLAY	DISPLAY HEIGHT	13 mm				
ALIMENTAZIONE DI RIFERIMENTO	RECOMMENDED SUPPLY VOLTAGE	12 Vdc				
ALIMENTAZIONE MAX.	MAX. SUPPLY VOLTAGE	15 Vdc				
ASSORBIMENTO MAX	MAX. ELECTRICAL INPUT	25 mA				
CONNETTORE DI ALIMENTAZIONE	POWER CONNECTOR	MIL PT02E10-6P				
VALORI MECCANICI LIMITE RIFERITI AL CARICO NOMINALE :	MECHANICAL LIMIT VALUES REFERRED TO NOMINAL LOAD :					
a) carico di servizio	a) service load	120%				
b) carico limite	b) max permissible load	150%				
c) carico di rottura	c) breaking load	>300%				
d) massimo carico trasversale	d) max transverse load	50%				
e) carico dinamico limite	e) max permissible dynamic load	75% ⁽¹⁾				
FRECCIA MAX. AL CARICO NOMINALE	DISPLACEMENT AT NOMINAL LOAD	-0.06mm	-0.09mm	-0.17mm	-0.17mm	-0.23mm
PESO	WEIGHT	~1.60 kg	~2.45 kg	~5.80 kg	~6.80 kg	~16.5 kg
CLASSE DI PROTEZIONE (EN 60529)	PROTECTION CLASS (EN 60529)	IP40				
MATERIALE DEL DINAMOMETRO	EXECUTION MATERIAL	Acciaio Inox / Stainless Steel				
LUNGHEZZA CAVO	CABLE LENGTH	5m				
VITI DI FISSAGGIO:	FIXING SCREWS					
a) diametro	a) diameter	M8	M10	M16	M16	M24
b) classe di resistenza	b) resistance class	12.9	12.9	12.9	12.9	12.9
c) coppia di serraggio	c) tightening torque	40 Nm	70 Nm	368 Nm	368 Nm	460 Nm

Test e calibrazioni eseguite in **COMPRESSIONE** con il dinamometro montato al supporto e viti di fissaggio correttamente serrate.

Tests and calibrations performed in **COMPRESSION** with the dynamometer mounted on a bearing support with correctly tightened clamping screws.

⁽¹⁾ Il carico dinamico deve essere applicato al filetto centrale del dinamometro e non sulla corona esterna di fissaggio.

The dynamic load must be applied to the dynamometer central thread and not to the external fixing rim.

Collegamenti Elettrici Electrical Connections

PIN	INPUT	CABLE (optional)	CAVO (opzionale)
A	POWER + (12Vdc)	Red	Rosso
B	POWER - (GND)	Black	Nero
F	EARTH ⁽¹⁾	Shield	Schermo

⁽¹⁾ Collegato al corpo del dinamometro. / Connected to the body of the dynamometer.

Applicazioni Applications

Per l'applicazione del dinamometro vedere il data sheet: **TC4.211**

For the dynamometer application please look at the data sheet: **TC4.211**

AEP transducers

Dasa-Rägister
EN ISO 9001 (2000)
IQ-1100-01

Centro SIT n° 93

ATEX
Production Quality
Assurance Certified n°
TÜV 06 ATEX 553793 Q

41010 Cognento (MODENA) Italy Via Bottego 33/A Tel:+39-(0)59-346441 Fax:+39-(0)59-346437 E-mail: aep@aep.it

Al fine di migliorare le prestazioni tecniche del prodotto, la società si riserva di apportare variazioni senza preavviso.

In order to improve the technical performances of the product, the company reserves the right to make any dynamometer without notice.

SYSTEM
TECHNOLOGY
SWEDEN AB

www.systemtech.se

Tel: 013-35 70 30

sales@systemtech.se