

La scatola di giunzione **SG4** viene utilizzata per semplificare impianti di pesatura, dosaggio e controllo dove è necessario collegare in parallelo più celle di carico per avere in uscita un unico segnale, rappresentante la somma dei segnali delle celle collegate.

Per realizzare tale parallelo sono state predisposte cinque morsettiere con serraggio a vite, utilizzate per eseguire i collegamenti elettrici dei cavi di ingresso e quello di uscita.

Il contenitore in alluminio pressofuso e i passacavi in dotazione garantiscono una classe di protezione IP65 (EN60529), contro la polvere e i getti d'acqua.

L'SG4 permette di eseguire collegamenti in parallelo di 4 celle di carico equipaggiate con sistemi a 4 o 6 fili.

SG4 junction box is used to make weighing, dosing and plants controlling easier, whenever connecting load cells in parallel is necessary, in order to have a single output signal which represents the sum of the signals of connected load cells.

To connect load cells in parallel, five terminal boards with screw-type clamping have been arranged and they are used to perform electrical connections of both input and output cables.

The case made of die-cast pressurized aluminium and the fairleads supplied with, ensure a IP65 protection class (EN60529) against dust and water jets.

SG4 enables to perform connections in parallel of 4 load cells with 4 or 6 wires systems.

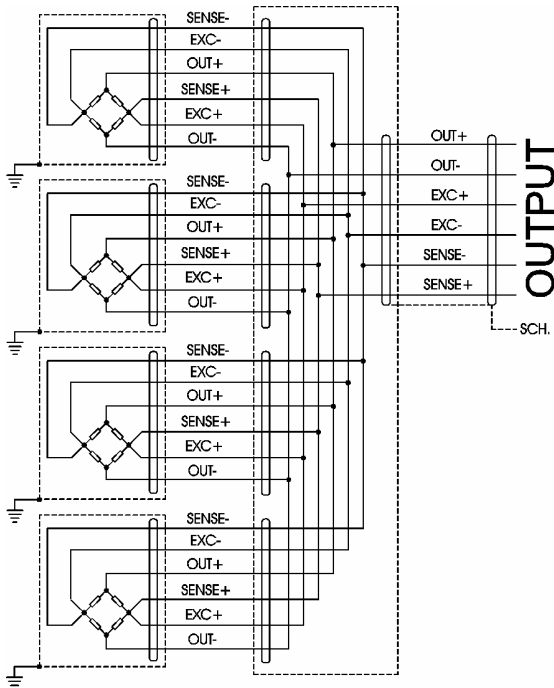

Load cells



2mV/V



RoHS
COMPLIANCE

2mV/V

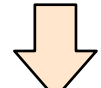

CE

4

Max celle di carico
Max. load cells

Aluminium

Contenitore
Case

IP65

Classe di protezione
Protection class

Dimensioni (H×L×P):	Dimensions (H×L×W):	80×125×58 mm
Peso:	Weight:	~0.6 kg

Codice: **ESG4**

Codice: **EPG7SET** Confezione di n° 3 passacavi metallici
Pack of No. 3 metal fairleads



**CONNESSIONI a 4 e 6 fili/
4 and 6 wires CONNECTIONS**

**Collegamenti (visti dal lato saldature)
/Connections (seen from
soldering side)**

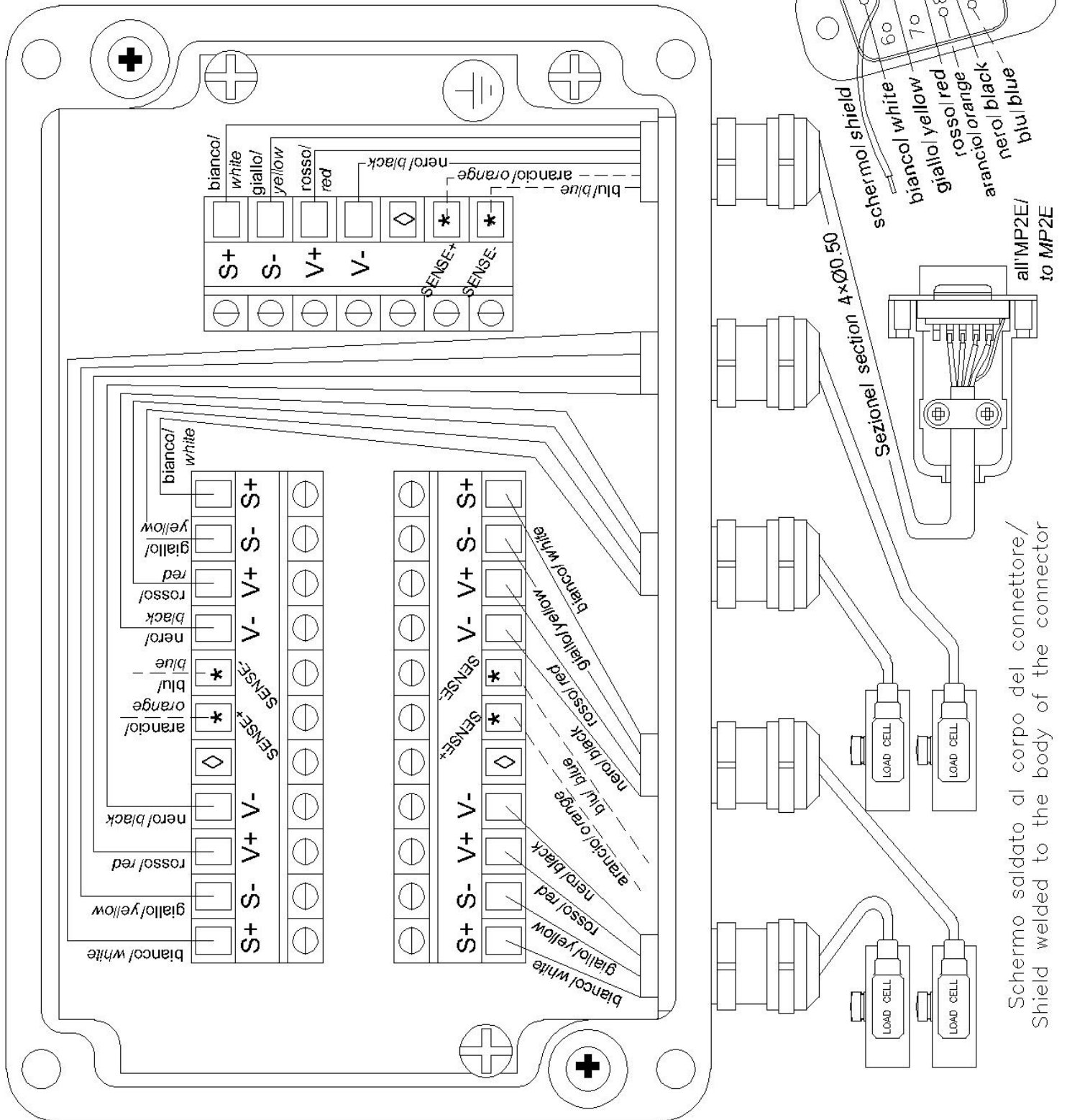

NOTE:

- * Si usano solo con collegamenti a sei fili / Used only with 6 wires connections
- ◊ Non collegare / Not to be connected
- + Fori di fissaggio / Fixing holes 2×Ø4.8 position 113×52