

Impact-E 150 AL



Features

The Impact-E 150AL is a compact, low power embedded system that utilises the Intel® Atom™ Apollo Lake processor series to achieve high performance with minimal power draw.

With such a low power requirement, this unit lends itself well to be powered by solar power or battery.

Key Features:-

- Low power consumption
- High processing power
- Compact design
- 3 year warranty



Dimensions

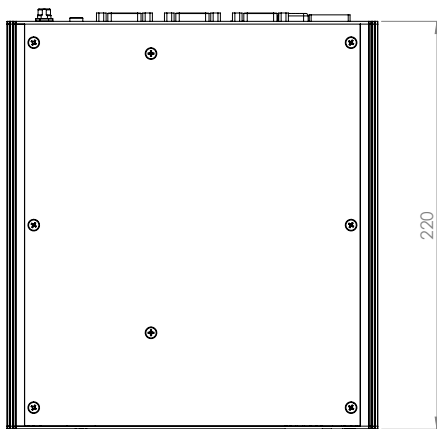

Plan View

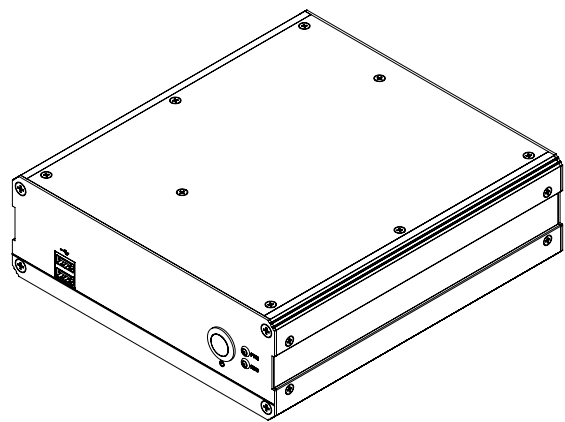

Front View

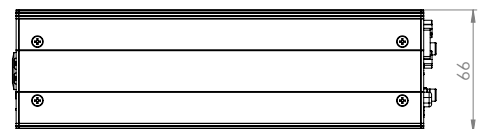

Side View

Impact-E 150 AL

Specifications

The information is believed to be accurate. However Amplicon Liveline Limited accepts no responsibility for any problems caused by errors and omissions. Specifications are subject to change without notice.

Hardware specification	Processor: Intel® ATOM™ x7-3950 Processor, Quad Core, 2M Cache, 1.6GHz (2.0GHz), 12W Memory: Dual SO-DIMM DDR3L up to 16GB Display: VGA and HDMI	Audio	Realtek ALC262-VC2-GR Line-Out via 3.5mm jack
BIOS	Insyde SPI 64bit	On-board LAN	Dual RJ45 GbE Intel® I21xAT PCIe (10/100/1000Mbps)
Storage	1 x 2.5" SSD/HDD 1 x M.2 ("B" Keyed)	Mechanical	Design: Rugged compact embedded design Cooling: Fanless design Construction: Extruded Aluminium Colour: Black Dimension: 200 x 66 x 220mm (W x H x D)
System expansion	1 x Full size mPCIe (PCIe/USB) 1x M.2	Environment	Operating Temperature: 0°C to 60°C Storage Temperature: -30°C to 80°C Operating Humidity: 5 to 90% RH Storage Humidity: 5 to 90% RH
Supported OS	Microsoft: Windows 10 (x64) Windows 10 IoT (x64) Linux: Yocto Project Ubuntu 15.10 Fedora 24	Power Input	100-240 VAC 1.5A 50-60Hz
I/O interfaces	Front I/O: USB: Dual stack USB 2.0 Rear I/O: Serial Port: COM1-6 USB: 2 x Dual stack USB 3 LAN: Dual GbE (Intel®) Display: HDMI and VGA Audio: Line-Out	Warranty	3 years
Display	Intel® HD Graphics GT Series VGA: up to 2560*1600@60Hz HDMI: up to 3840*2160@30Hz Support for DirectX 12, OpenCL 2.1, OpenGL 5.0	Electromagnetic compatibility (EMC)	

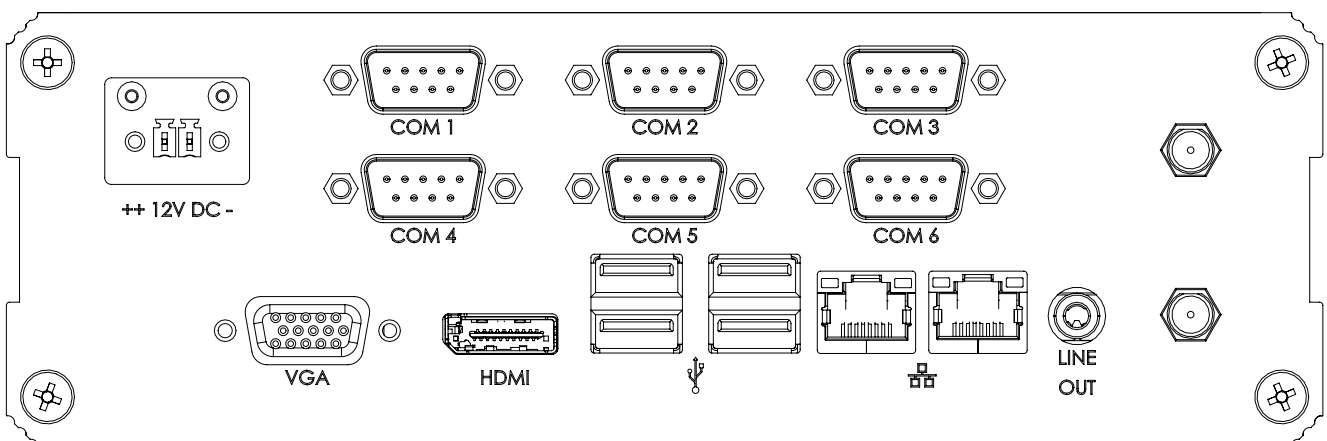

www.systemtech.se

Tel: 013-35 70 30
sales@systemtech.se
Linnégatan 14 • 582 25 LINKÖPING

Sales: +44 (0) 1273 570 220 Admin: +44 (0) 1273 608 331 Fax: +44 (0) 1273 570 215 Website: www.amplicon.com Email: sales@amplicon.com